



**ELECTRIC/HYDRAULIC PUMPS**

---

**UP-45SV (G)**

**-8 Series**

**Operation and maintenance manual**

**NITTOH ZOHKI CO.,LTD.**

102,4-10,2-Chome,Kamezawa,Sumida-ku,  
Tokyo 130,Japan

Telephone.03-3625-6551

Facsimile. 03-3625-6553



**INDEX**

- 1. Safety information ----- 2 page
- 2. Description of components ----- 4
- 3. Instructions before use ----- 5
- 4. Operation ----- 5
- 5. Maintenance ----- 6
- 6. Circuits -----10
- 7. Construction drawings -----11
- 8. Parts lists -----13
- 9. Trouble shooting guide -----15
- 10. Warranty -----16



# 1 Safety Information

Read and follow all WARNINGS, CAUTIONS and INSTRUCTIONS included with each product to use the products correctly and to avoid personal injury or property damage during system operation. NITTOH ZOHKI CANNOT BE RESPONSIBLE FOR DAMAGE OR INJURY RESULTING FROM UNSAFE USE OF PRODUCTS, LACK OF MAINTENANCE OR INCORRECT SYSTEM APPLICATION.

Cautions remarks used in this manual are classified as follows;

 DANGER	In case as the result of incorrect use in disregard of this remarks, imminent danger may happen, causing the risk of death or serious injury.
 WARNING	In case as the result of incorrect use in disregard of this remarks, there will be a possibility that an operator will die or receive a serious wound.
 CAUTION	In case as the result of incorrect use in disregard of this remarks, there will be a possibility that an operator will receive an injury or material damage only will happen.

## Cautions when installed

 WARNING	
<ul style="list-style-type: none"><li>■ Install a pump unit for better balance.</li></ul>	<p>Since the reservoirs of totally enclosed rubber structure are used in this series pumps, the pumps can be placed for use in every direction (slant, inversion or perpendicular). However, the pumps should be installed on stable places. When a pump is used aslant, fix it firmly with. Otherwise, it slide down, causing an injury.</p>
<ul style="list-style-type: none"><li>■ Prepare good working environment.</li></ul>	<p>Make sure all system components are protected from external sources of damage such as excessive heat, flame, moving machine parts, sharp edges, corrosive chemicals.</p>
 CAUTION	
<ul style="list-style-type: none"><li>■ Do not use the pump in the rain or on such wet or dusty places.</li><li>■ Do not expose hydraulic system to the direct rays of the summer's sun.</li></ul>	<p>Be careful with unacceptable rise in hydraulic oil temperature, causing trouble of hydraulic equipment.</p> <ul style="list-style-type: none"><li>■ In case the pumps are used outdoors in the extremely cold regions, exchange oil for hydraulic oil of proper viscosity.</li></ul> <p>Increased viscosity due to drop in oil temperature, there is the possibility that equipment gets out of order.</p>

## Caution when used



### WARNING

■ Take safety measures.

When hydraulic equipment is operated, protect yourself with a personal safeguard, working clothes and shoes, safety spectacles, etc.

■ Always check pressure limitations of hydraulic circuit.

Always confirm in advance that max. permissible working pressure of a hydraulic pump is lower than the pressure rating of the lowest rated component connected in the system.

■ Be careful to avoid electric shock.

Do not pull power plug out with a wet hand. Use a grounded outlet or a plug adapter with a grounding attachment in order to protect the operator from electric shock. Do not operate the pump by the side of electric welder or do not place it on the earthed materials or equipment.



### CAUTION

■ Power supply is AC220V 50/60Hz single phase.

Make sure your line voltage must be the same as the voltage your pump is wired for. Wrong voltage connection or voltage drop of your line shall cause burning or heating. Be careful about voltage drop when used with an electric generator.

■ When the power supply is disconnected, always grasp the power plug and pull it out.

Disconnection by grasping the cord and pulling it out will cause breaking of a wire or a short circuit.

■ When a supplement cord is used, use only three-wire grounded cords of such sufficient gauge as 1.25mm<sup>2</sup> or more, its length of max. 10M, in order to avoid voltage drop or damage of the solenoid valves or electric motors.

## Specifications

Model, No	Electric motor	Hydraulic pump				Reservoir
		Max, Work pressure MPa		Flow Rate L/min(50Hz)		
UP-45SVG -8H (L) -8A(L) -8SP(L) -8WP(L) -8R(L)	Commutator and open type, 0.45KW 220V 50/60Hz single phase, “E” insulation, 2000rpm, Max. 4.5A	1 <sup>st</sup> stage	2 <sup>nd</sup> stage	1 <sup>st</sup> stage	2 <sup>nd</sup> stage	Capacity 3.0L (5.0L) Usable 2.0L (4.0L)
		7	70	2.5	0.35	

## 2 Description of components

### UP-45SVG-8H.8A

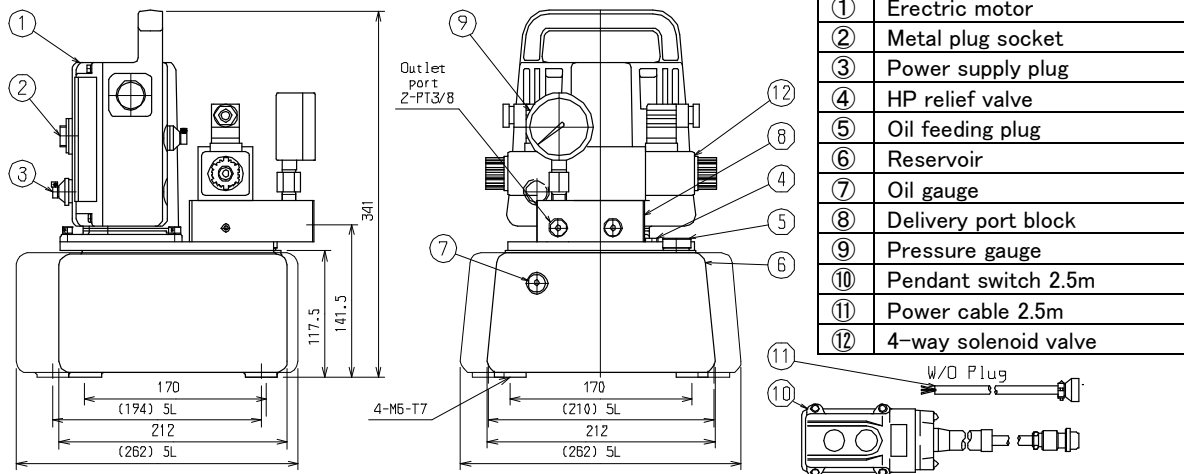

### UP-45SVG-8SP.8WP

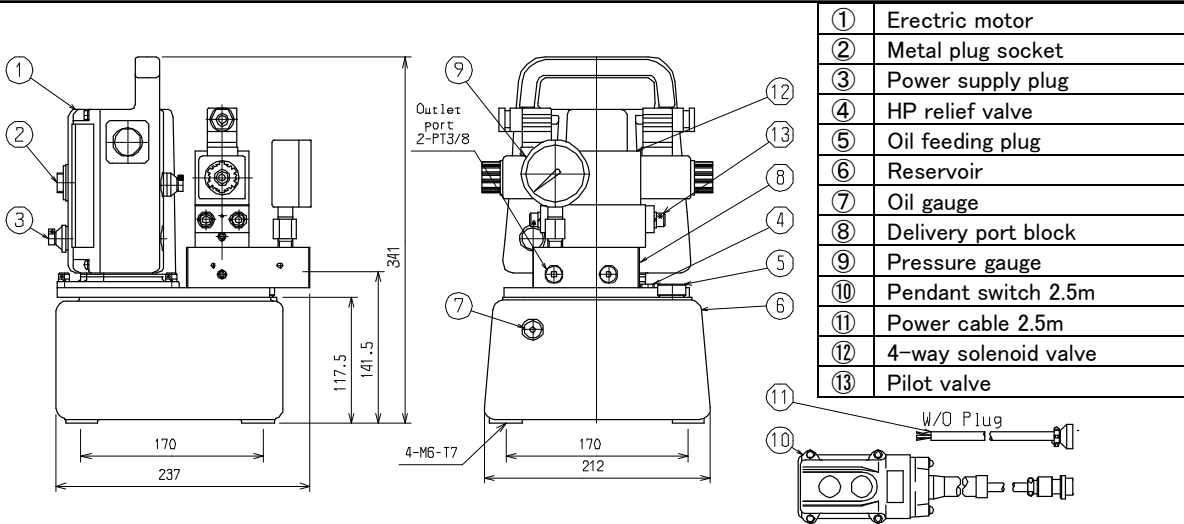

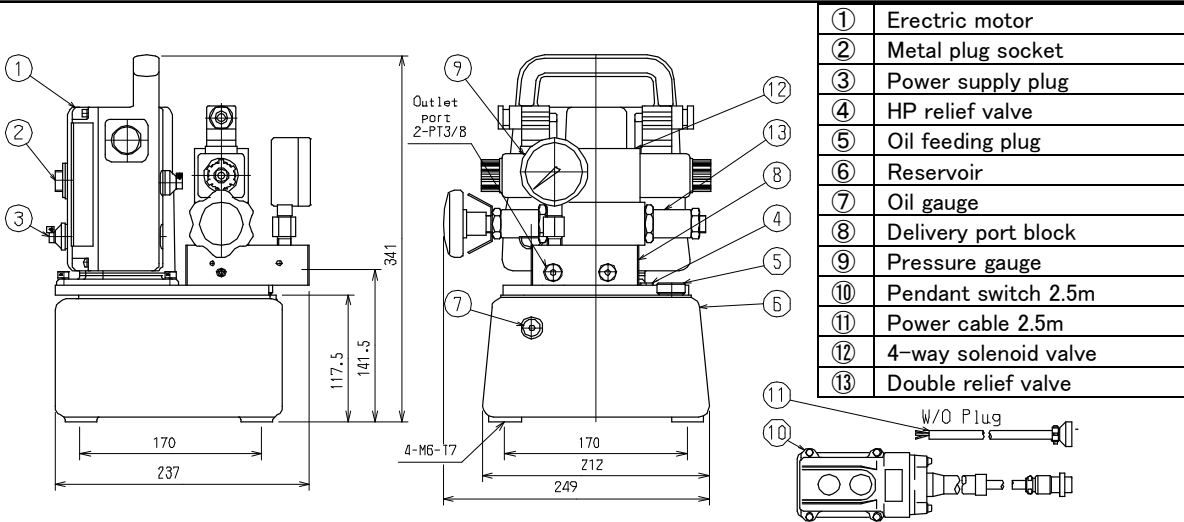

### UP-45SVG-8R



## 3 Instructions before use

3-1 Confirmation of all components for shipping damage or oil leakage. If any shipping damage is found, notify carrier at once. Shipping damage is not covered by warranty. The carrier is responsible for all repair or replacement costs resulting from damage in shipment.

3-2 Oil feeding plug  CAUTION  
Use it after 2~3 turns loosens a plug.

3-3 Confirmation of your power supply  WARNING  
Power supply is 220V 50/60Hz single phase. Make sure that a grounded outlet or a plug adapter with a grounding attachment must be used.

3-4 Confirmation of hydraulic oil  WARNING  
Always check oil level before operation, with the connected cylinders fully retracted (extended if pull cylinders). In case oil is added with cylinders fully extended and then cylinders are retracted, the returned oil will overflow in the reservoirs, causing generation of high pressure in the reservoirs, confirm required oil volume in a reservoir as follows:

- ① Retract the connected cylinder fully.
- ② Check the oil gauge and confirm if oil is feeded up to half of the gauge. If oil is short, not reaching the half of the level gauge, replenish oil. (See 5-1 kind of hydraulic working oil).

## 4 Operation

**“UP-45SVG-8H/8A”** with SVS-4A or SVS-4H 4-way 3-position solenoid valve. Advance/Retract.

- 1 Plug in the pump.
- 2 Depress “A” switch to run the motor and to advance the cylinder (flow to port “A” ,port “B” returns flow to the reservoir). The motor stops with “A” switch released.
- 3 Depress “B” switch to retract the cylinder. UP-45SVG-8A pump allows stopping of the cylinder, but can not hold pressure. UP-45SVG-8H has all ports open solenoid valve.

**“UP-45SVG-8SP/8WP”** with SVS-4H 4-way 3-position solenoid valve and VPCS-10 or VPCW-10 pilot-operated check valve. Advance/Hold/Retract.

- 1 Plug in the pump.
- 2 Depress “A” switch to run the motor and to advance the cylinder (flow to port “A” port “B” returns flow to the reservoir). The motor stops with “A” switch released.
- 3 Depress “B” switch to run the motor and to retract the cylinder (flow to port “B”, port “A” returns flow to the reservoir). UP-45SVG-8SP pump allows pressure holding of port “A” by means of single pilot-operated check valve, while UP-45SVG-8WP can hold pressure on both ports “A” and “B” by pilot-operated check valves.

“UP-45SVG-8R” with SVS-4H 4-way 3-position solenoid valve and WDRL-10 relief valve. Advance/Hold/Retract.

- 1 Plug in the pump.
- 2 Depress “A” switch to run the motor and to advance the cylinder (flow to port “A” port “B” returns flow to the reservoir). The motor stops with “A” switch released.
- 3 Depress “B” switch to run the motor and to retract the cylinder (flow to port “B”, port “A” returns flow to the reservoir).
- 4 Pressure of both ports “A” and “B” can be adjusted by means of relief valves. They can not hold pressure, but it is possible to convert into pressure holding type pumps by adding pilot-operated check valves.

## 5 Maintenance

### 5-1 Hydraulic working oil

#### ① Kind of oil

Use only Nittoh NHO-32 hydraulic oil or an approved, high-grade oil (ISO #32, viscosity : 32 cSt @40° C) with these pumps to promote long pump life.

#### ② Oil temperature

Appropriate temperature for use of hydraulic oil is max. 55° C. In case it happens unacceptable rise in oil temperature, stop working so as to decrease oil temperature or take such a measure as installation of an oil cooler.

#### ③ Oil exchange CAUTION

The frequency of oil change will depend upon general working conditions, severity of use and overall cleanliness. 300 hours (working time) of use or about 3 months is considered as a standard change interval. Periodically compare samples of the reservoir oil with new oil and inspect oil color for contaminants or differences.

Remove oil feeding plug and tilt the pump to drain out old oil. Be careful that such impurities as dusts do not enter into the reservoir and new oil is filled up to the gauge level mark shown on pump. Precautions when oil changed are;

- Retract all cylinders fully to the return position.
- Do not fill with even a small quantity of replenishment of different kinds of oil.
- Be careful that impurities or foreign matter do not enter into new oil.

#### ④ Others WARNING

When oil enters into a eye, wash it away fully with clean water and consult a doctor immediately. In case oil enters into the skin of such a wound, wash it away with soapy water and consult a doctor without delay.

## 5-2 Pressure and piping

### ① Composition of hydraulic equipment system



WARNING

When a pump, high-pressure hose(s), cylinder, valve, couplings are connected together, always check product limitations regarding pressure ratings and load capacities. The system operating pressure must not exceed the pressure rating of the lowest rated component in the system.

### ② Pressure gauges

Always install or prepare a pressure gauge in-line from the pump in order to check pressure developed.

### ③ Piping



CAUTION

Use wrapping of Teflon tape on hoses fittings, valves and couplers. Make sure all hose connections are tight-use proper tools to tighten connections with reference to the following table. Do not over tighten the connections.

NPT,PT sizes	Tightening torque N-m(kgf-m)
1/8"	13-14 (1.3-1.4)
1/4"	30-40 (3.0-4.0)
3/8"	60-70 (6.0-7.0)
1/2"	100-110 (10.0-11.0)

Make sure that tape not shed into hydraulic system, causing damage. Trim loose ends.

## 5-3 High pressure hoses

### ① Hose installation



WARNING

Install hoses, leaving something in reserve, because high-pressure hoses expand and contract more or less when full pressure is applied. Be careful that the hoses do not rub against other solid materials.

Never allow the hoses to kink, twist, curl or bend so tightly that oil flow within hoses are blocked or restricted. Do not clamp the hoses, causing troubles.

### ② Hose handling



DANGER

Never drop heavy things against the hoses, causing bursting of hoses or serious accident. Do not subject the hoses to any potential hazard (fire, extreme heat or cold, heavy impact or sharp surfaces), which might rupture or weaken the hoses. Never pull hoses to move or lift equipment connected with hoses.

Should a hose ever burst or ruptured, immediately stop operating the pump before attempting to remedy the situation. Never attempt to grasp a leaking hose under pressure with your hands. The force of the escaping hydraulic fluid could cause serious and permanent injury.



## 5-4 Quick couplers

### ① Connections

Make sure that all couplers are connected properly. Incomplete coupling connections might cause partial or complete blockage of oil flow, resulting in trouble of hydraulic system.

### ② Handling



WARNING

Stop operating of the pump with a hose and coupler, but without a cylinder. The damaged coupler will cause accident. Do not disconnect the coupler sets, which are under pressure.

## 5-5 Bleeding air from the system



CAUTION

In case a new cylinder and/or a hose is connected with the pump or hydraulic oil is exchanged, air may accumulate in the hydraulic system. This air will cause the pump not deliver oil or the cylinder to respond in an unstable or slow manner. To remove this air;

- (a) The cylinder(s) must be positioned on their side with the couplers located upward.
- (b) Remove any load from the cylinder(s) and cycle the hydraulic system through several cycles (fully extend and retract the cylinders) or intermittently 2 to 3 minutes.

## 5-6 Carbon brushes

### ① Cautions when in use



WARNING

Always check the wearing condition of the carbon brushes. When the carbon brushes have been worn down and exchanging time has come, the motor will stop automatically. Replace when a carbon brush has been worn down to 6mm in length as shown below or working time of the motor is 150 hours or more subject to the conditions of their uses. Use only NITTOH carbon brushes with these pumps to promote long pump life. When they have been worn down, the spring exerts insufficient pressure to hold brush against the commutator.

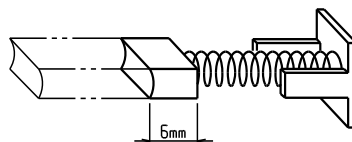

### ② How to change

Firstly disconnect the power supply. Remove rubber caps on two places and loosen and remove fitting screws inside with a screw driver, so the carbon brushes can be taken out. Replace with new ones and fix the screws and rubber caps.

## **5-7 Relief valve adjustment**

Range of standard pressure adjustment available is from 58.8 to 68.6MPa. different kind of a spring is needed to adjust and set at lower pressure than the standard. Contact NITTOH authorized distributor.

Loosen lock screw on the relief valve and turn the adjusting screw a few turns counter-clockwise to decrease pressure setting to a lower desired pressure. Clockwise rotation of the adjusting screw will increase pressure.

# 6 Circuits

UP-45SVG-8A/8H Hydraulic Circuit	Electric Circuit
UP-45SVG-8SP/8WP Hydraulic Circuit	Electric Circuit
UP-45SVG-8R Hydraulic Circuit	Electric Circuit

# 7 Construction drawings

The pump part is an attached sheet (Drawing attachment).

The valve part mentions it according to a model as follows.

## UP-45SVG-8H/8A

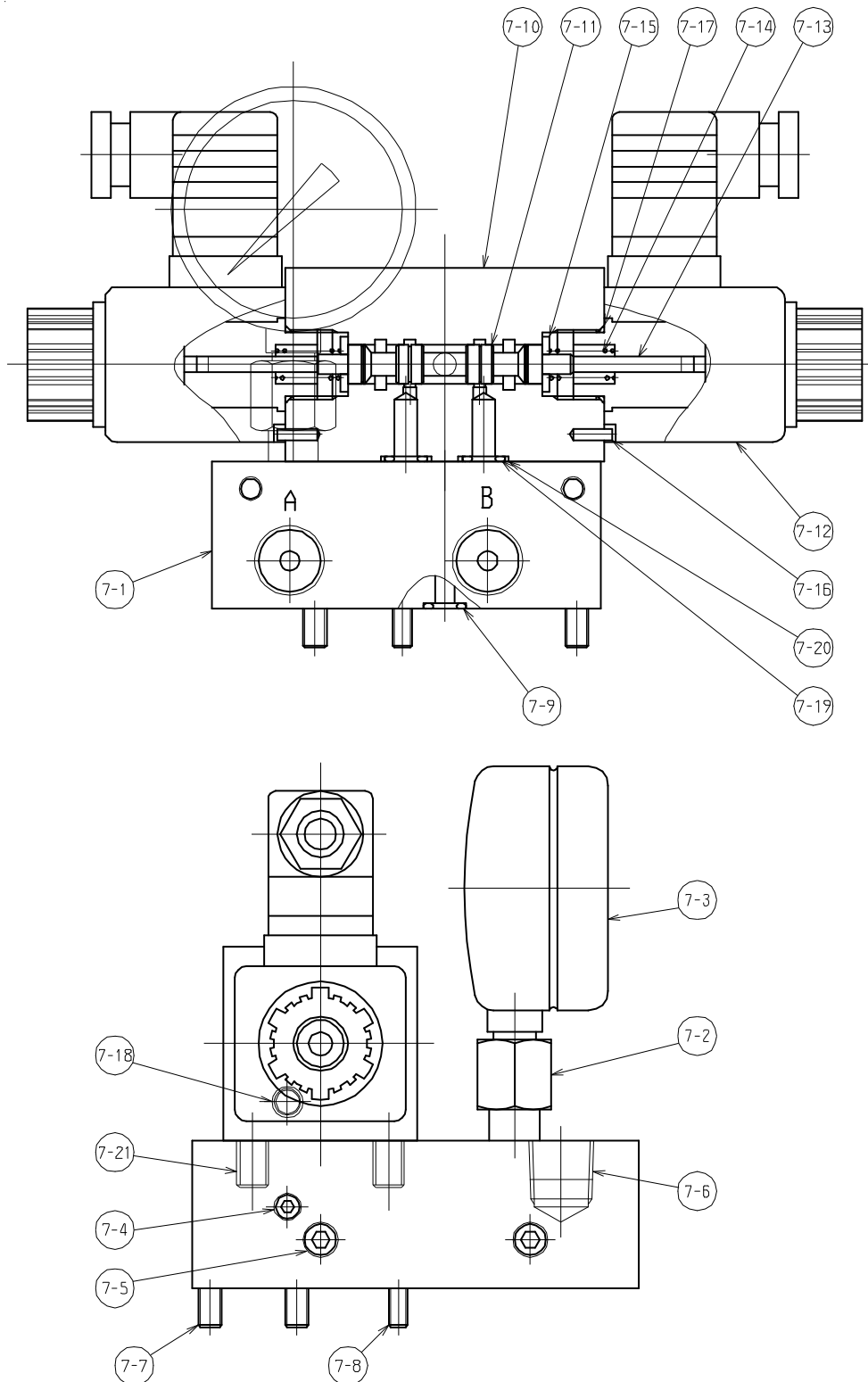

**VPCW-10 (UP-45SVG-8WP/8SP) Pilot check valve**

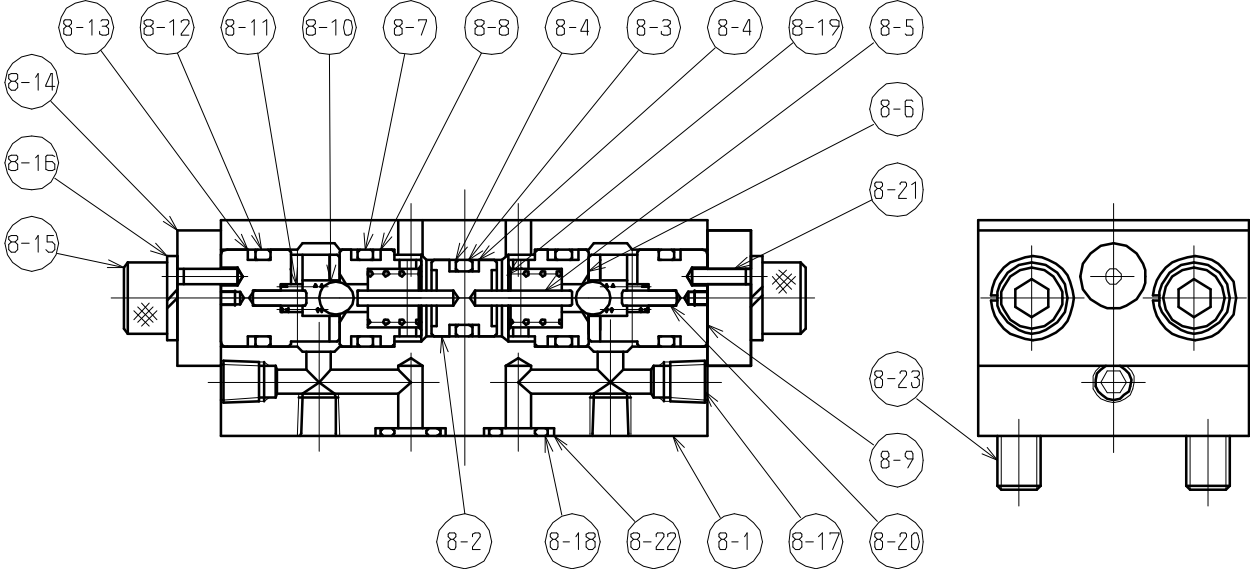

**VDRL-10 (UP-45SVG-8R) Double relief valve**

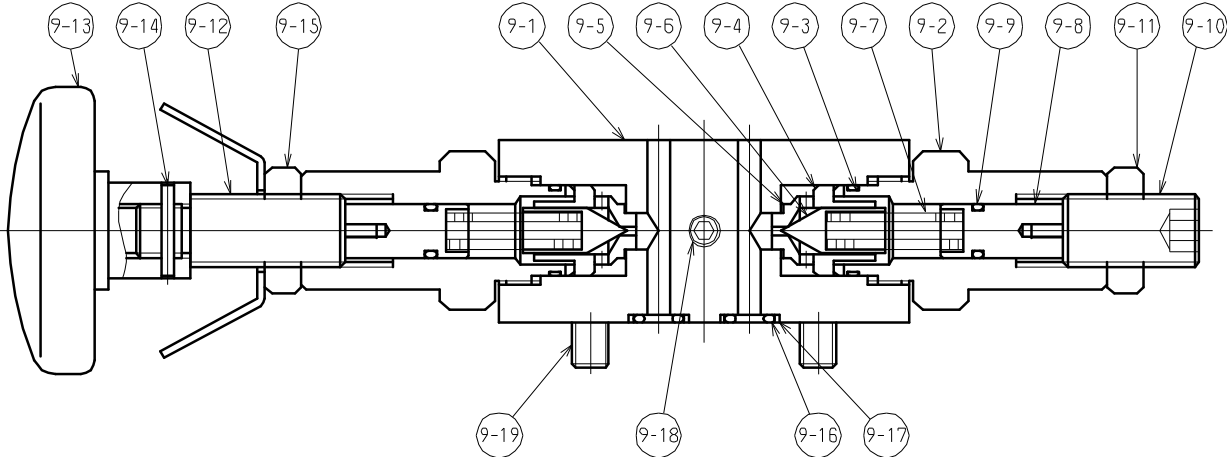

## 8 Parts list

No.	Part No.	Description	HL valve portion		
Driving portion			2-1	$\phi 5$	Steel ball
1-1	1P50155	Pump body	2-2	WY5-10	Spring
1-2	TLA1616Z	Bearing	2-3	4P53854	Retainer
1-3	AC0687A0	Oil seal	2-4	$\phi 7$	Steel ball
1-4	4P53051	Low pres, piston	2-5	WF6-25	Spring
1-5	4P53052	High pres, piston	2-6	4P53855	Retainer
1-6	UF-8.5-20	Spring	2-7	4P50636	Copper packing
1-7	4P50636	Copper packing	2-8	MSWA12	Blind plug
1-8	4P52942	Blind plug	2-9	PT1/8×PS1/4	L fitting
1-9	MSWA12	Screw plug	2-10	4P50664	Filter
1-10	4P52943	Eccentric collar	2-11	$\phi 5$	Steel ball
1-11	RNAF253517	Bearing	2-12	WY5-10	Spring
1-12	NTB1629	Thrust bearing	2-13	4P53854	Retainer
1-13	AS1629	Thrust washer	2-14	$\phi 7$	Steel ball
1-14	$\phi 4 \times 30$	Spring pin	2-15	WF6-25	Spring
1-15	4P52944	Driving shaft	2-16	4P53855	Retainer
1-16	G-16	G type ring	2-17	4P50636	Copper packing
1-17		Key	2-18	MSWA12	Blind plug
1-18		2 Gear	2-19	MB700-070	Expander
1-19	MUM-S8-1	Electric motor	Unloader portion		
1-20		Carbon brush	3-1	$\phi 1/4$	Steel ball
1-21		Screw cap	3-2	TB8-15	Spring
1-22	4P52995	Rubber plug	3-3	4P52949	Adjusting screw
1-23	M6	Spring washer	3-4	M10	Lock nut
1-24	M6×15	Fitting bolt	3-5	SL-M5	Air filter
1-25	SCK2003R	Metal plug socket	3-6	4P53050	Push pin
1-26	M3×10	Screw	3-7	$\phi 4 \times 15.8$	Needle roller
1-27	OA-05	Cap cone	3-8	P-4	O ring
1-28	M4	Spring washer	3-9	P-4	Back-up ring
1-29	M4×10	Fitting bolt	3-10	4P50636	Copper packing
1-30	MB700-040	Expander	3-11	4P52951	Blind plug
1-31	MB700-050	Expander	3-12	MSWA12	Blind screw
1-32	PT1/16	Blind plug	3-13	USA-4-10	Spring
1-33	P-8	O ring	Relief valve portion		
1-34	4P53053	Return pipe	4-1	$\phi 2.5$	Steel ball
1-35	UHP-16	Hole plug	4-2	4P51889	Ball receiver
1-36	4P53055	Guide plate	4-3	TB8-15	Spring
1-37	M5×10	Fitting bolt	4-4	4P51980	Spring pusher
1-38	M5	Spring washer	4-5	P-6	O ring

4-6	MSWA12	Pushing screw
4-7	M4×10	Lock screw
Tank portion		
5-1	1P50156	Reservoir 3L
5-2	KCM-20	Oil gauge
5-3	G-140	O ring
5-4	M6	Spring washer
5-5	M6×10	Fitting bolt
5-6	4P54343	Feeding plug
5-7	P-16	O ring
5-8	PT3/8	Blind screw
5-9	1P50165	Reservoir 5L
Electrical parts portion		
6-1		Power cord
6-2	SCK2003P	Plug socket
6-3	COB61	Pendant control switch
6-4		DC power supply
6-5		Printed board Assy
6-6	M3×6	Fitting bolt
<b>UP-45SVG-8H/8A</b> Valve portion		
7-1	2P50484	Manifold
7-2	7-1	Gauge adaptor
7-3	φ 63-100MPa	Pressure gauge
7-4	PT1/16	Blind plug
7-5	PT1/8	Blind plug
7-6	PT3/8	Blind plug
7-7	M6×45	Fitting bolt
7-8	M5×45	Fitting bolt
7-9	P-8	O ring
7-10	3P50502	Valve body
7-11-1	4P52049	Spool shaft (8H)
7-11-2	4P52050	Spool shaft (8A)
7-12	W-22B	Solenoid
7-13	4P52053	Push pin
7-14	4P51083	Spring
7-15	4P52051	Spring receiver
7-16	φ 4×10	Spring pin
7-17	P-15	O ring
7-18	PT1/16	Blind plug
7-19	P-7B	O ring
7-20	4P52908	Back-up ring
7-21	M8×35	Fitting bolt

<b>VPCW-10 (UP-45SVG-8WP/8SP)</b>		
8-1	3P50563	Check valve body
8-2	4P54491	Piston
8-3	P-10A	O ring
8-4	P-10A	Back-up ring
8-5	φ 3×17.8F	Push pin
8-6	4P53489	Valve seat
8-7	P-14	O ring
8-8	P-14	Back-up ring
8-9	4P53492	Valve seat retainer
8-10	φ 1/4	Steel ball
8-11	WL5-10	Spring
8-12	P-14	O ring
8-13	P-14	Back-up ring
8-14	4P52249	Retaining plate
8-15	M8×15	Fitting bolt
8-16	M8	Spring washer
8-17	PT1/16	Blind plug
8-18	P-7B	O ring
8-19	4P53488	Spring
8-20	MS3-10	Parallel pin
8-21	MS3-10	Parallel pin
8-22	4P52908	Back-up ring
8-23	M8×75	Fitting bolt
<b>VDRL-10 (UP-45SVG-8R)</b>		
9-1	3P50555	Relief valve body
9-2	4P52258	Relief case
9-3	S-18	O ring
9-4	4P52259	Valve seat
9-5	4P50434	Copper packing
9-6	4P50624	Needle valve
9-7	SWB8-35	Spring
9-8	4P52260	Spring pushing piece
9-9	P-9	O ring
9-10	4P52261	Adjusting screw 1
9-11	M16P2	Lock nut 2
9-12	4P52262	Adjusting screw 2
9-13	EK63	Handle
9-14	φ 3×20	Spring pin
9-15	4P52263	Lock nut 1
9-16	P-7B	O ring
9-17	4P52908	Back-up ring
9-18	PT1/16	Blind plug
9-19	M8×75	Fitting bolt

## 9 Trouble shooting guide



WARNING

- To prevent injuries, any repair work or trouble-shooting must be done by qualified personnel familiar with this kind of equipment. Use the proper gauges and device.

Problems	Possible Causes	Remedies
Motor does not run  WARNING Disconnect power supply before disassembly or repair.	(1) No supply voltage. (2) Broken lead wire or defective power cord plug. (3) Defective switches. (4) Worn carbon brushes. (5) Defective motor. (6) Defective remote switch. (7) Unit is not plugged in.	(1) Check line voltage. (2) Replace defective partd. (3) Check switches. (4) Replace carbon brushes. (5) Repair or replace motor. (6) Repair or replace switch. (7) Plug in unit.
Abnormal noise of motor.	(1) Damage or pump or motor. (2) Damage of ball bearings, etc.	(1) Repair or replace unit. (2) Replace ball bearings.
Motor runs, but cylinders do not advance or retract.	(1) Damage of release valve. (2) Oil level is too low. (3) Air in system. (4) Filter plugged or dirt in pump. (5) Damage of pump body. (6) Damage or out of adjustment of relief valve.	(1) Repair or replace it. (2) Fill reservoir to 1/2 of level gauge with all cylinders retracted. (3) Bleed the system. (4) Pump filter should be cleaned and if necessary, pump should be dismantled and cleaned. (5) Repair pump. (6) Repair or readjust as needed.
Cylinders works, but full pressure is not built up.	(1) Damage of release valve. (2) Air in system. (3) Damage of pump body. (4) Lowering of set pressure or damage of relief valve.	(1) Repair or replace. (2) Bleed the system. (3) Repair pump. (4) Readjustment of set pressure or repair of relief valve.
Cylinders works, but their speed too slow, partially or erratically.	(1) Damage of release valve. (2) Air in system. (3) Unacceptable rise in oil temperature. (4) Damage of pump body.	(1) Repair or replace. (2) Bleed the system. (3) Stop operation or install oil cooler. (max. 55°C) (4) Repair pump.
Cylinders do not retract.	(1) Damage of release valve. (2) Damage of return springs of cylinders or quick couplers.	(1) Repair or replace. (2) Repair or replace springs or couplers.
Oil leaks.	Damage seals, seats or steel balls.	Replace them.
Short circuit.	(1) Damage cords. (2) Bad insulation of electric parts.	(1) Replace. (2) Replace.



# 10 Warranty

## 9-1 Warranty period

It is for one year from purchase.

## 9-2 Warranty

All NITTOH products and parts, with the exception mentioned below, are warranted against defects in materials and workmanship, which results in damage to products and parts. This warranty shall cover repair and/or replacement of the products or components/parts free of charge. To qualify for warranty consideration, return the NITTOH product, freight prepaid, to a NITTOH factory. Refer to the NITTOH STANDARD EXPRESS WARRANTY for the details.

## 9-3 Warranty exceptions

No warranty claim will be accepted for damage or breakdown arising for any of the following reasons.

“Abuse or improper use, fair wear and tear, faulty or negligent operation, improper storage, chemical/ electrical influences or climatic or other effects which can not be related specially to faults in manufacture”

No liability is accepted for packing seals, springs, and/ or the like, and the following:

- ◎ Alterations or remodeling on the products undertaken by the purchasers without any prior notice and agreement to NITTOH.
- ◎ Severe and very highly frequent use, deviating from product specifications.
- ◎ Damage due to faulty installation or assembly by purchasers or third parties.
- ◎ Damage from natural disaster.
- ◎ Damage from such accidents as fire, submersion, dropping, etc.