

# ELECTRIC HYDRAULIC PUMP

## UP-45SV series

### Model : UP-45SVG-1

- Standard Tank Oil : 3.0 Litres
- Effective Oil : 2.0 Litres



### Model : UP-45SVG-4L

- Large Tank Oil : 5.0 Litres
- Effective Oil : 4.0 Litres



## *Small size*

- Lightweight, compact and easy to carry, making it very convenient when working on site.
- Since it is compatible with single-phase 100V~230V power supply, it can be used anywhere in the field.
- Two-speed operation reduces cycle times for improved productivity.
- The low pressure discharge volume is 2.5 liters per minute, so work can be done quickly.
- With abundant variations of accessories, UP45 can be used for various purposes.
- An optional pressure switch for safety control can be attached to all pumps.

# Single Acting

## UP-45SVG-1

UP-45SVG-1 (Pressure gauge, Standard tank 3ℓ)

UP-45SVG-1L (Pressure gauge, L tank 5ℓ)

UP-45SVS-1 (Pressure gauge, Pressure Switch, Standard tank 3ℓ)

UP-45SVS-1L (Pressure gauge, Pressure Switch, L tank 5ℓ)



<b>Valve type</b>	Manual 2way-2position Holding type
<b>Switch</b>	Pendant switch / ON button only
<b>Feature</b>	For Single Acting Cylinder by manual 2 way valve

### Advance

When the manual valve lever is set to the right, and press ON of the pendant switch, the motor rotates, and the cylinder advances. When ON switch is released, the cylinder can be stopped and hold on advance.

### Retraction

When the manual valve lever is set to the left, the cylinder returns. There is no OFF button.

Model	Electric Motor	Mortor kW (2,000rpm)	Voltage(AC) 50Hz/60Hz	Amps	Output Flow Rate(Lpm)		Oil Volume (Litre)		Weight (Including oil)
					7Mpa(70Bar)	70Mpa(700Bar)	Tank	Effective	
<b>UP-45SVG-1</b>	Commutator, Single phase	0.45	220/230	4.5	2.5	0.35	3.0	2.0	16.1Kg
			100/110	9.0					
<b>UP-45SVG-1L</b> (Large Tank)			220/230	4.5					
			100/110	9.0					

### <Dimensions> (mm)

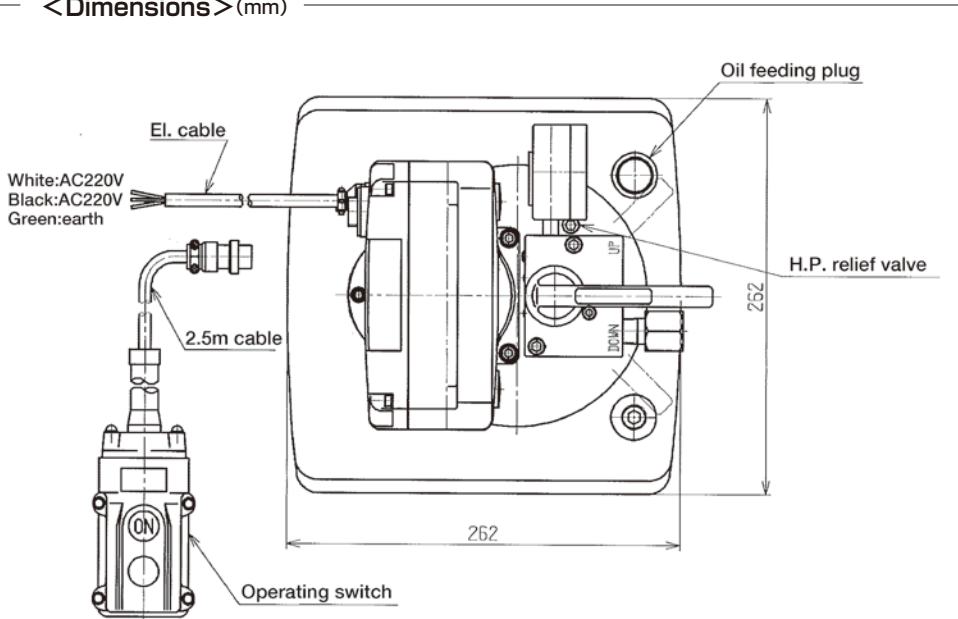

### <Hydraulic circuit>

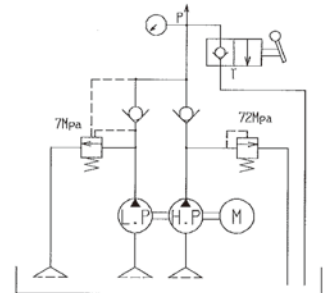

### <Electric circuit>

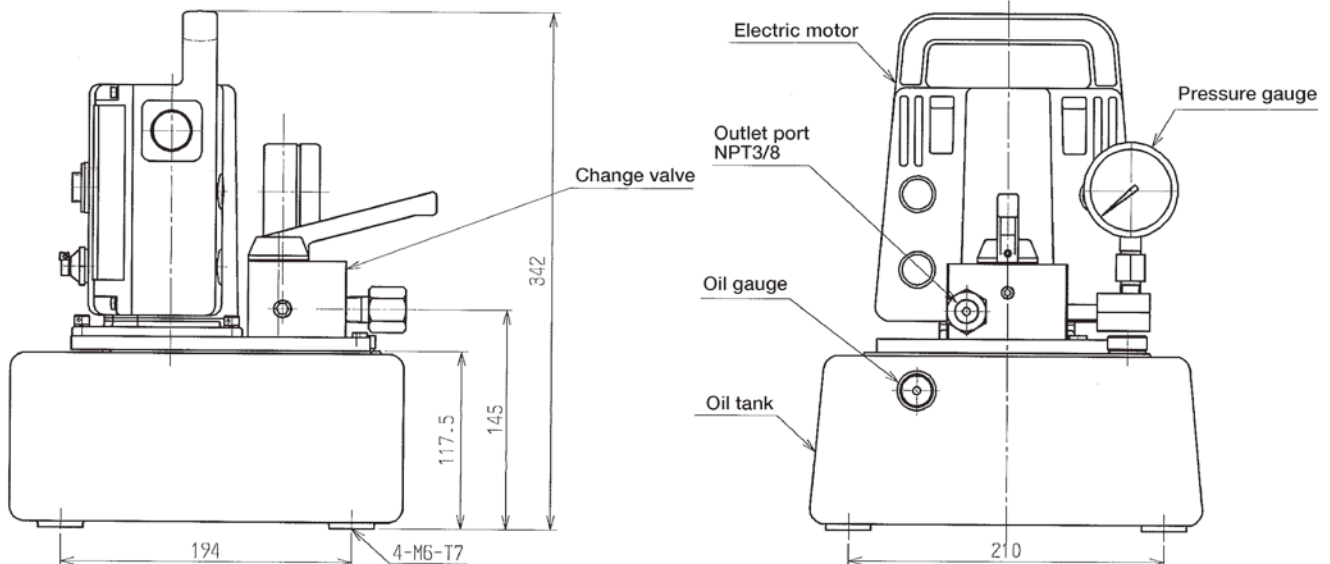
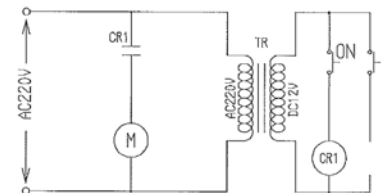

# Single Acting

## UP-45SVG-3M

UP-45SVG-3M (Pressure gauge, Standard tank 3 ℓ)

UP-45SVG-3ML (Pressure gauge, L tank 5 ℓ)

UP-45SVS-3M (Pressure gauge, Pressure Switch, Standard tank 3 ℓ)

UP-45SVS-3ML (Pressure gauge, Pressure Switch, L tank 5 ℓ)



<b>Valve type</b>	Manual Needle Valve, Holding type
<b>Switch</b>	Pendant switch / ON button only
<b>Accessories</b>	Pressure Gauge Ø60
<b>Feature</b>	For Single Acting Cylinder by Manual Needle Valve, Hold on retraction

### Advance

When the manual needle valve is closed and press ON the pendant switch, the motor rotates and the cylinder advances.

### Retraction

When the manual needle valve is opened and the cylinder will return. When the manual needle valve is closed and the cylinder will stop. You can gradually lower the cylinder, so it is suitable for jacking up etc. There is no OFF button.

Model	Electric Motor	Mortor kW (2,000rpm)	Voltage(AC) 50Hz/60Hz	Amps	Output Flow Rate(Lpm)		Oil Volume (Litre)		Weight (Including oil)			
					7Mpa(70Bar)	70Mpa(700Bar)	Tank	Effective				
<b>UP-45SVG-3M</b>	Commutator, Single phase	0.45	220/230	4.5	2.5	0.35	3.0	2.0	16.1Kg			
			100/110	9.0								
<b>UP-45SVG-3ML</b> (Large Tank)			220/230	4.5						5.0	4.0	18.5Kg
			100/110	9.0								

### <Dimensions> (mm)

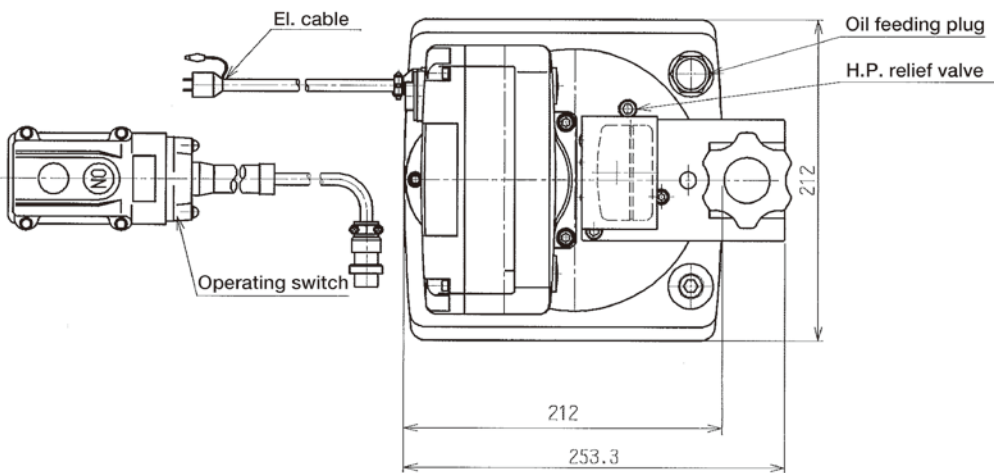

### <Hydraulic circuit>

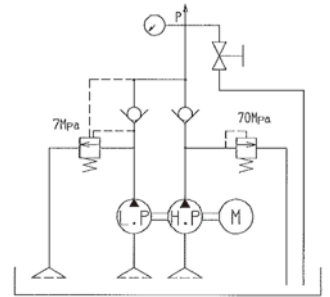

### <Electric circuit>

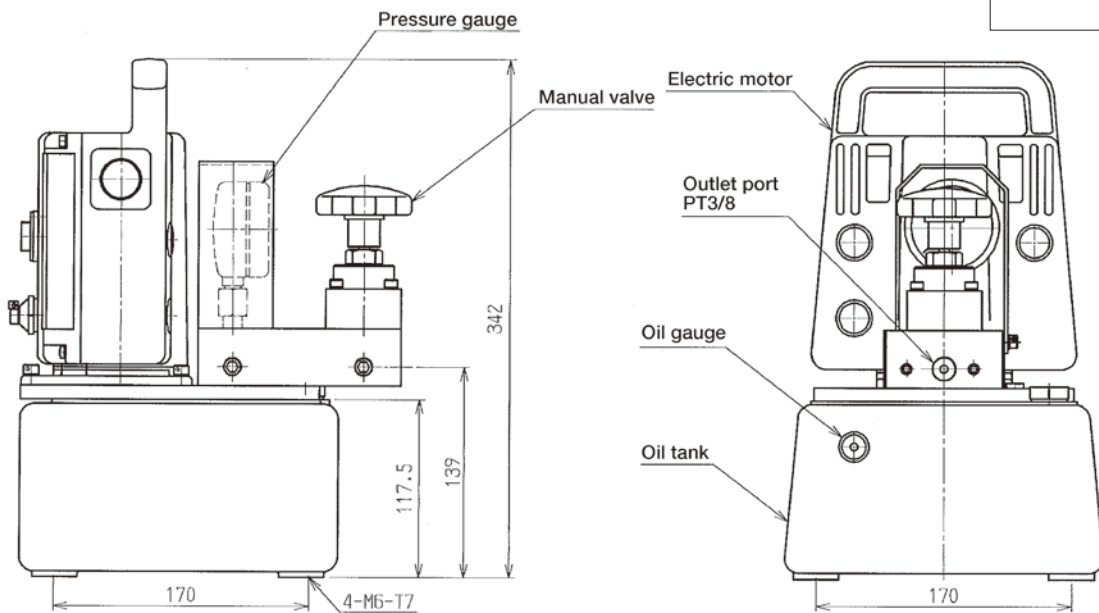
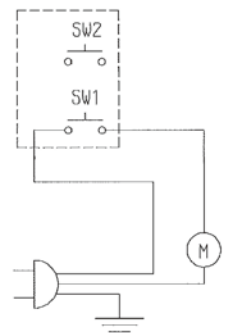

# Single Acting

## UP-45SVG-4

UP-45SVG-4 (Pressure gauge, Standard tank 3 ℓ)

UP-45SVG-4L (Pressure gauge, L tank 5 ℓ)

UP-45SVS-4 (Pressure gauge, Pressure Switch, Standard tank 3 ℓ)

UP-45SVS-4L (Pressure gauge, Pressure Switch, L tank 5 ℓ)



<b>Valve type</b>	Solenoid	<b>Holding type</b>	
<b>Switch</b>	Pendant switch / On and Off button		
<b>Accessories</b>	Pressure Gauge Ø60		
<b>Feature</b>	For Single Acting Cylinder by Solenoid valve. Ideal for lifting, Jacking up.		

### Advance

When ON switch is pressed, then the motor starts as well as a cylinder extends. When ON switch is released, the cylinder can be stopped and hold on advance.

### Retraction

When OFF switch is pressed, then the cylinder starts to retract. When OFF switch is released, the cylinder can be stopped on retraction.

Model	Electric Motor	Mortor kW (2,000rpm)	Voltage(AC) 50Hz/60Hz	Amps	Output Flow Rate(Lpm)		Oil Volume (Litre)		Weight (Including oil)			
					7Mpa(70Bar)	70Mpa(700Bar)	Tank	Effective				
<b>UP-45SVG-4</b>	Commutator, Single phase	0.45	220/230	4.5	2.5	0.35	3.0	2.0	17.2Kg			
			100/110	9.0								
<b>UP-45SVG-4L</b> (Large Tank)			220/230	4.5						5.0	4.0	19.6Kg
			100/110	9.0								

### <Dimensions> (mm)

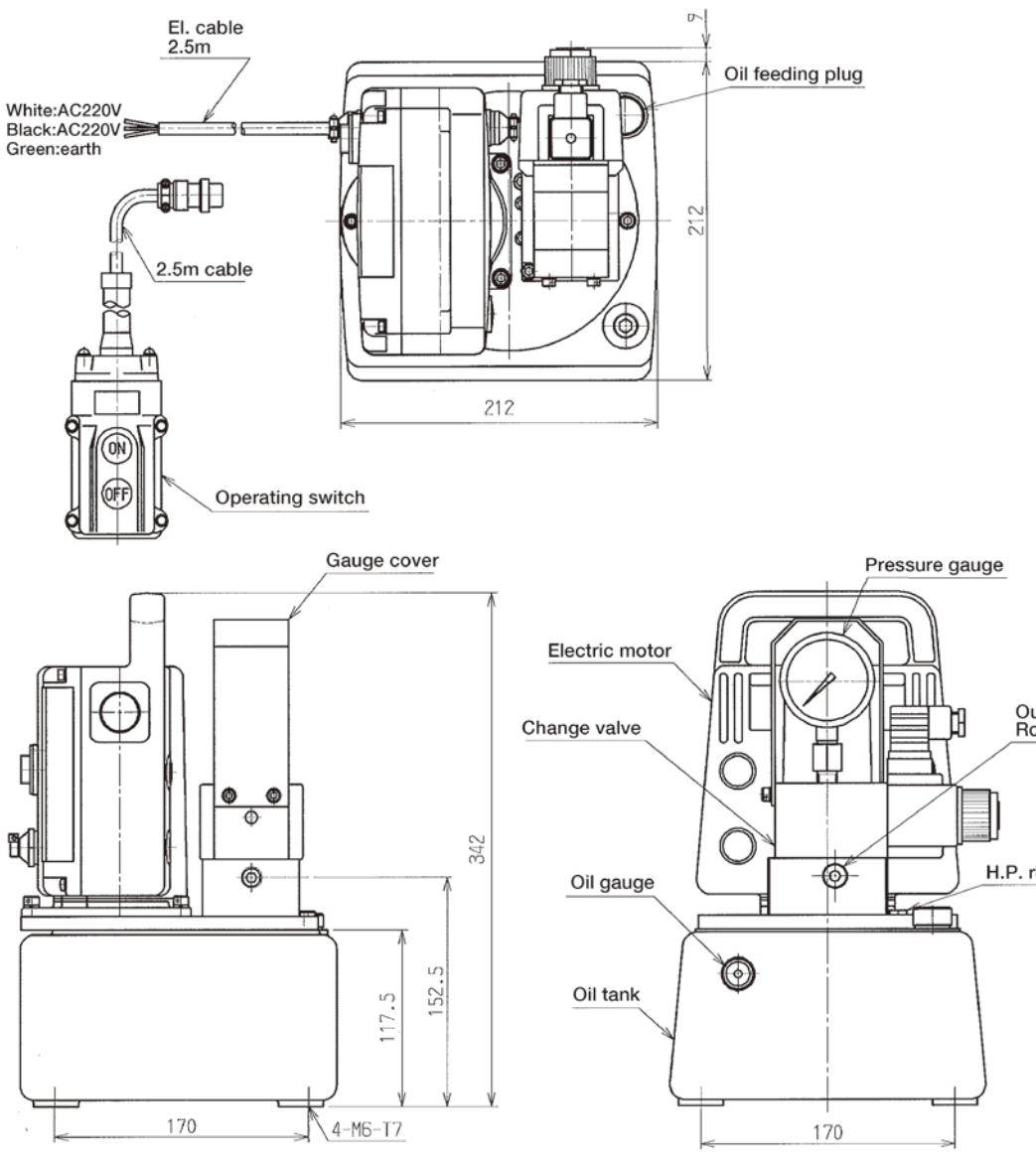

### <Hydraulic circuit>

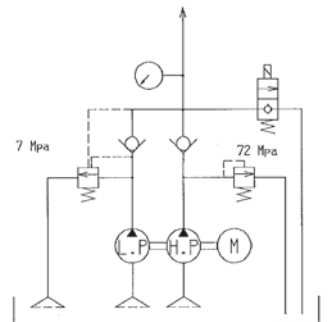

### <Electric circuit>

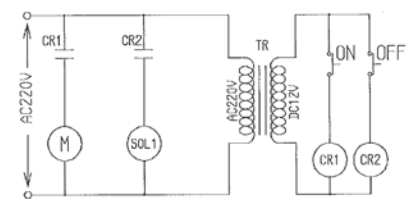



# Single Acting

## UP-45SVG-2

UP-45SVG-2 (Pressure gauge, Standard tank 3ℓ)

UP-45SVG-2L (Pressure gauge, L tank 5ℓ)

UP-45SVS-2M (Pressure gauge, Pressure Switch, Standard tank 3ℓ)

UP-45SVS-2L (Pressure gauge, Pressure Switch, L tank 5ℓ)



<b>Valve type</b>	Solenoid Auto return type
<b>Switch</b>	Pendant switch / ON button only
<b>Accessories</b>	Pressure Gauge Ø60
<b>Feature</b>	For Single Acting Cylinder by Solenoid valve.

### Advance

When ON switch is pressed, then the motor starts as well as a cylinder extends.

### Retraction

When ON switch is released, the cylinder automatically retracts at once. The cylinder cannot be stopped on retraction. There is no "OFF" button.

Model	Electric Motor	Mortor kW (2,000rpm)	Voltage(AC) 50Hz/60Hz	Amps	Output Flow Rate(Lpm)		Oil Volume (Litre)		Weight (Including oil)
					7Mpa(70Bar)	70Mpa(700Bar)	Tank	Effective	
<b>UP-45SVG-2</b>	Commutator, Single phase	0.45	220/230	4.5	2.5	0.35	3.0	2.0	18.5Kg
			100/110	9.0					
<b>UP-45SVG-2L</b> (Large Tank)			220/230	4.5	5.0	4.0	20.9Kg		
			100/110	9.0					

### <Dimensions> (mm)

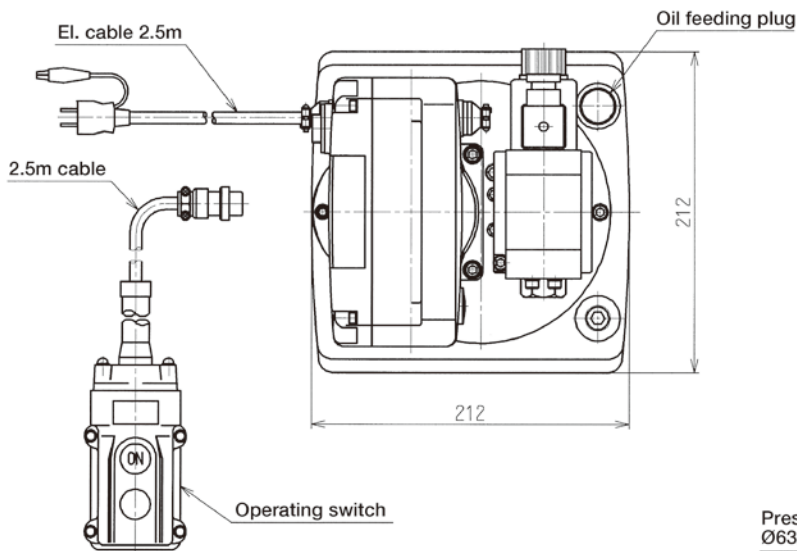

### <Hydraulic circuit>

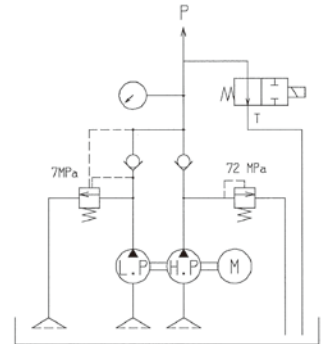

### <Electric circuit>

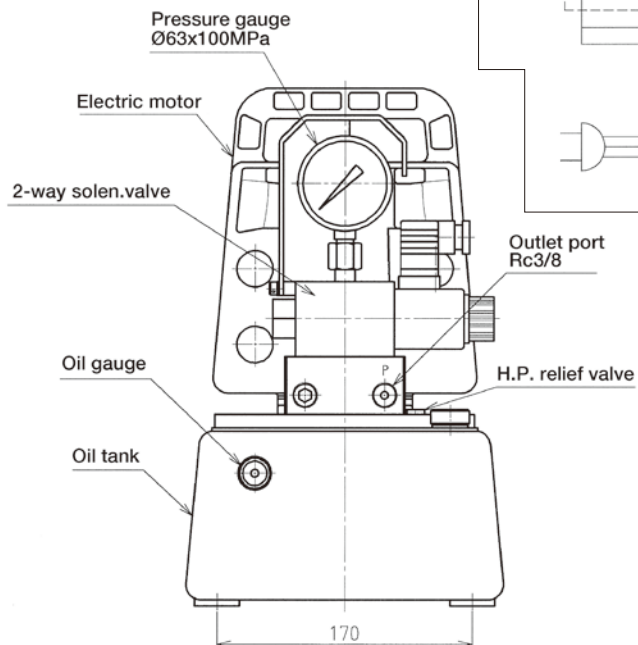
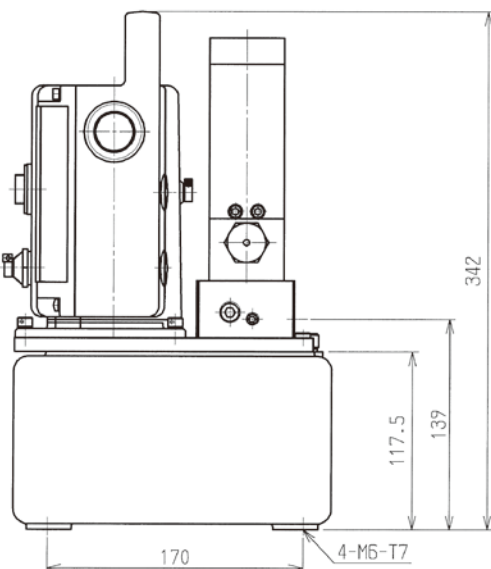
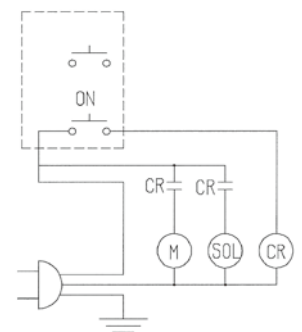

# Double Acting

## UP-45SVG-7

UP-45SVG-7 (Pressure gauge, Standard tank 3 ℓ)

UP-45SVG-7L (Pressure gauge, L tank 5 ℓ)

UP-45SVS-7 (Pressure gauge, Pressure Switch, Standard tank 3 ℓ)

UP-45SVS-7L (Pressure gauge, Pressure Switch, L tank 5 ℓ)



<b>Valve type</b>	Manual 4way-3position Holding type
<b>Switch</b>	Pendant switch / ON button only
<b>Accessories</b>	Pressure Gauge Ø60
<b>Feature</b>	For Double Acting cylinder by manual valve.

### Advance

When the manual valve lever is set to the left (A), and press ON of the pendant switch, the motor rotates, and the cylinder advances. When ON switch is released, the cylinder can be stopped and hold on advance.

### Retraction

When the manual valve lever is set to the right (B), and press ON of the pendant switch, the motor rotates, and the cylinder retracts. When ON switch is released, the cylinder can be stopped and hold on retraction.

Model	Electric Motor	Mortor kW (2,000rpm)	Voltage(AC) 50Hz/60Hz	Amps	Output Flow Rate(Lpm)		Oil Volume (Litre)		Weight (Including oil)			
					7Mpa(70Bar)	70Mpa(700Bar)	Tank	Effective				
<b>UP-45SVG-7</b>	Commutator, Single phase	0.45	220/230	4.5	2.5	0.35	3.0	2.0	16.1Kg			
			100/110	9.0								
<b>UP-45SVG-7L</b> (Large Tank)			220/230	4.5						5.0	4.0	18.5Kg
			100/110	9.0								

### <Dimensions> (mm)

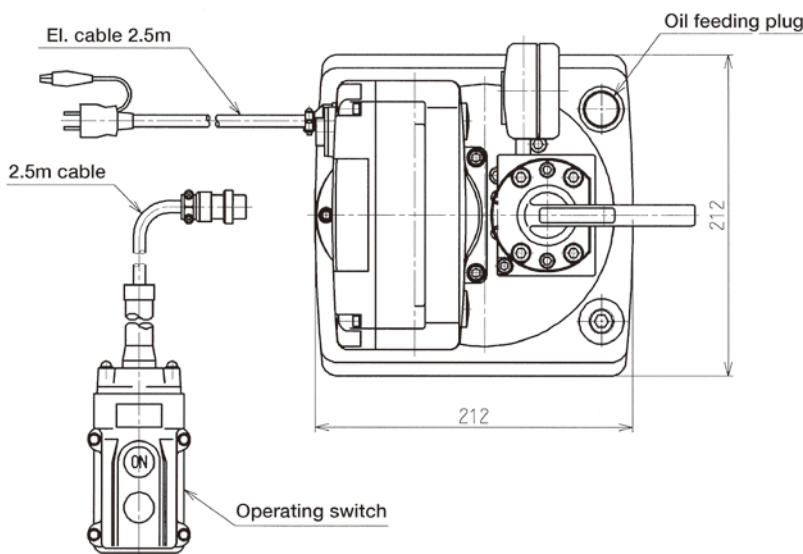

### <Hydraulic circuit>

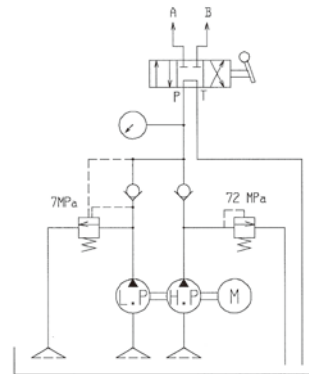

### <Electric circuit>

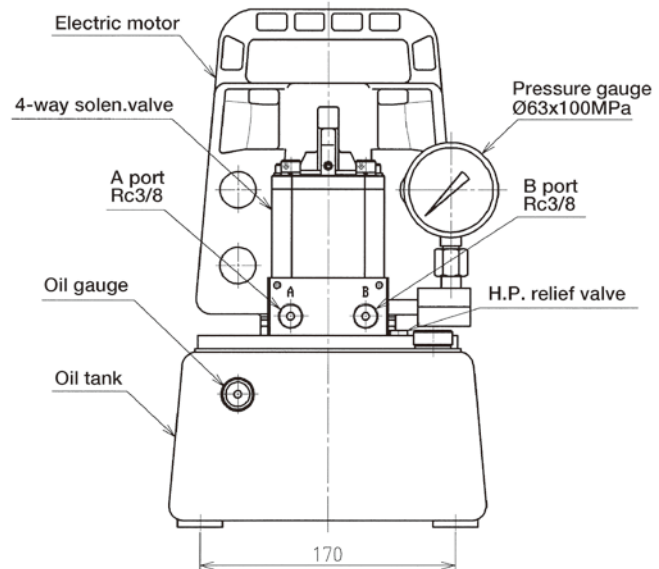
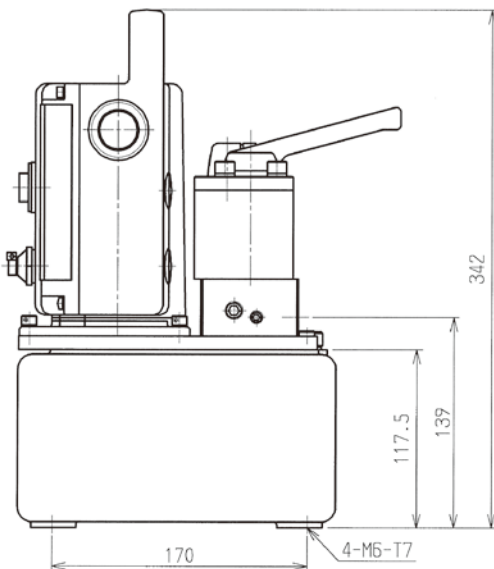
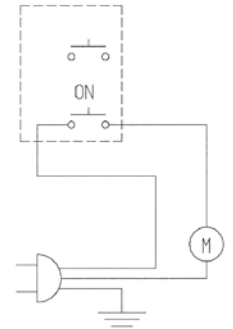

# Double Acting

## UP-45SVG-8SP UP-45SVG-8WP

- UP-45SVG-8SP(8WP) (Pressure gauge, Standard tank 3ℓ)
- UP-45SVG-8SPL(8WPL) (Pressure gauge, L tank 5ℓ)
- UP-45SVS-8SP(8WP) (Pressure gauge, Pressure Switch, Standard tank 3ℓ)
- UP-45SVS-8SPL(8WPL) (Pressure gauge, Pressure Switch, L tank 5ℓ)



<b>Valve type</b>	Solenoid 4way-3position Holding type
<b>Switch</b>	Pendant switch / A and B button
<b>Accessories</b>	Pressure Gauge Ø60
<b>Feature</b>	For Double Acting cylinder by solenoid valve.

### Advance

When A switch is pressed, then the motor starts as well as a cylinder extends. When ON switch is released, the cylinder can be stopped and hold on advance.

### Retraction

When B switch is pressed, then the cylinder starts to retract. When B switch is released, the cylinder can be stopped on retraction.

- 8SP model : Can be hold on A port
- 8WP model : Can be hold on A & B port

Model	Electric Motor	Mortor kW (2,000rpm)	Voltage(AC) 50Hz/60Hz	Amps	Output Flow Rate(Lpm)		Oil Volume (Litre)		Weight (Including oil)			
					7Mpa(70Bar)	70Mpa(700Bar)	Tank	Effective				
<b>UP-45SVG-8SP/8WP</b>	Commutator, Single phase	0.45	220/230	4.5	2.5	0.35	3.0	2.0	19.0Kg			
			100/110	9.0								
<b>UP-45SVG-8SPL/8WPL</b> (Large Tank)			220/230	4.5						5.0	4.0	21.4Kg
			100/110	9.0								

### <Dimensions> (mm)

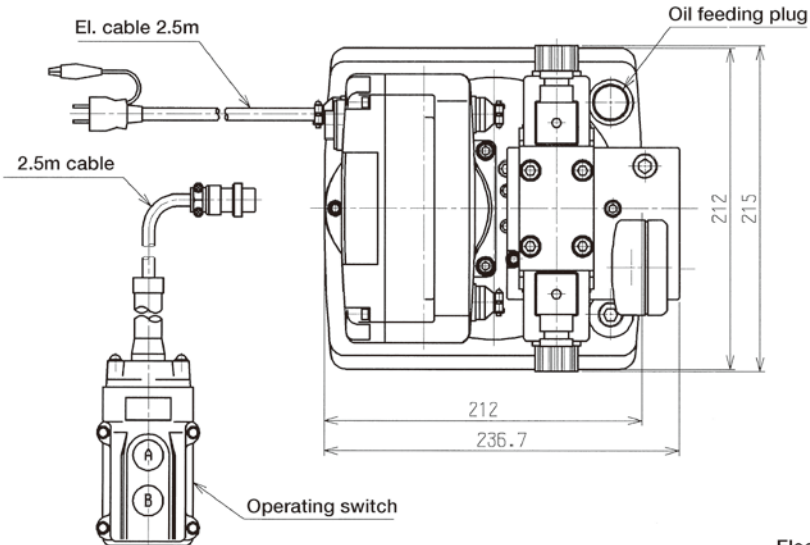

### <Hydraulic circuit>

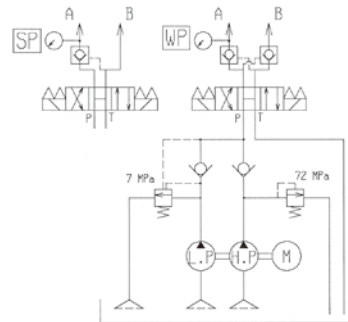

### <Electric circuit>

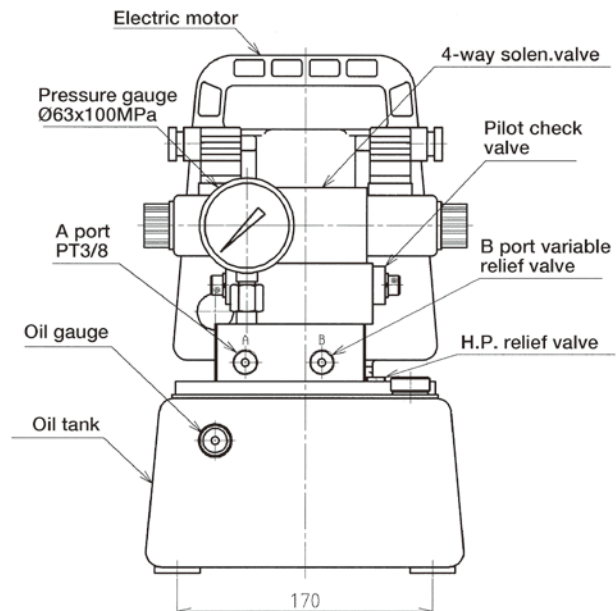
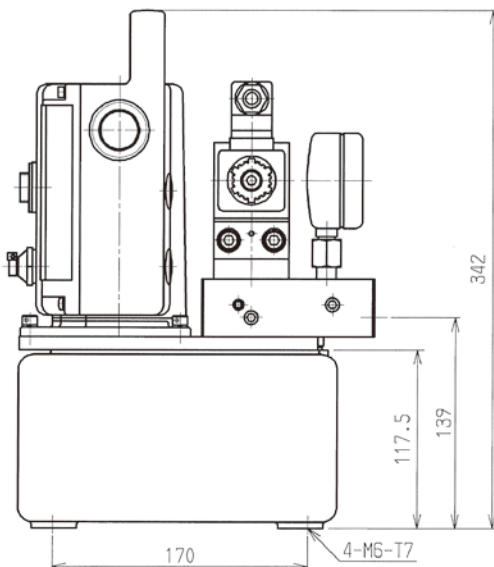
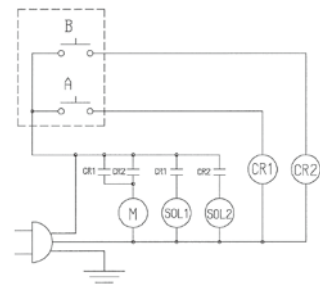

# Double Acting

## UP-45SVG-8R

UP-45SVG-8R (Pressure gauge, Standard tank 3 ℓ)

UP-45SVG-8RL (Pressure gauge, L tank 5 ℓ)



**Valve type** Solenoid 4way-3position Adjustable pressure relief valve

**Switch** Pendant switch / A and B button

**Accessories** Pressure Gauge Ø60

**Feature** Adjustable pressure both A port and B port by relief valve. For Double Acting cylinder by solenoid valve.

### Advance

When A switch is pressed, then the motor starts. When A switch is released, the cylinder can be stopped. (NOT hold pressure)

### Retraction

When B switch is pressed, then the cylinder starts to retract. When B switch is released, the cylinder can be stopped on retraction. (NOT hold pressure) \*By additional pilot check valve, pressure can be hold. (on request)

Model	Electric Motor	Mortor kW (2,000rpm)	Voltage(AC) 50Hz/60Hz	Amps	Output Flow Rate(Lpm)		Oil Volume (Litre)		Weight (Including oil)	
					7Mpa(70Bar)	70Mpa(700Bar)	Tank	Effective		
<b>UP-45SVG-8R</b>	Commutator, Single phase	0.45	220/230	4.5	2.5	0.35	3.0	2.0	21.0Kg	
			100/110	9.0						
<b>UP-45SVG-8RL</b> (Large Tank)			220/230	4.5			5.0	4.0		22.4Kg
			100/110	9.0						

### <Dimensions>(mm)

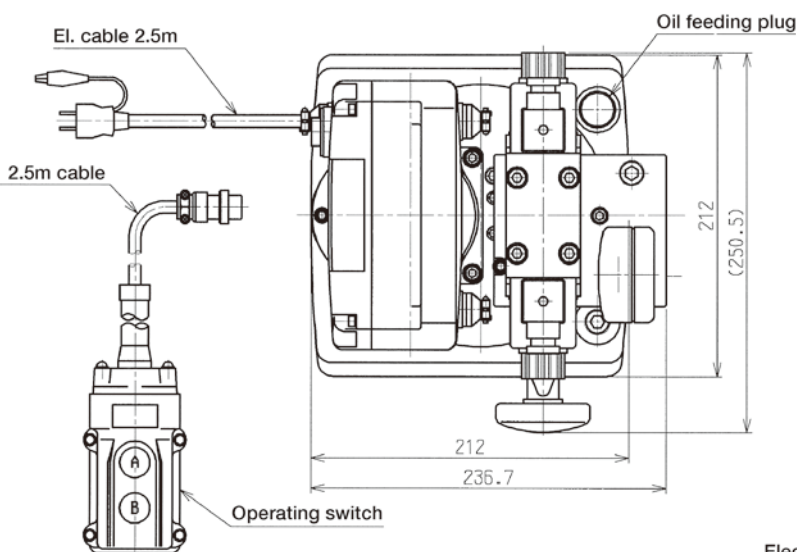

### <Hydraulic circuit>

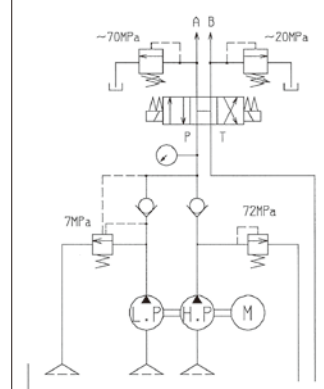

### <Electric circuit>

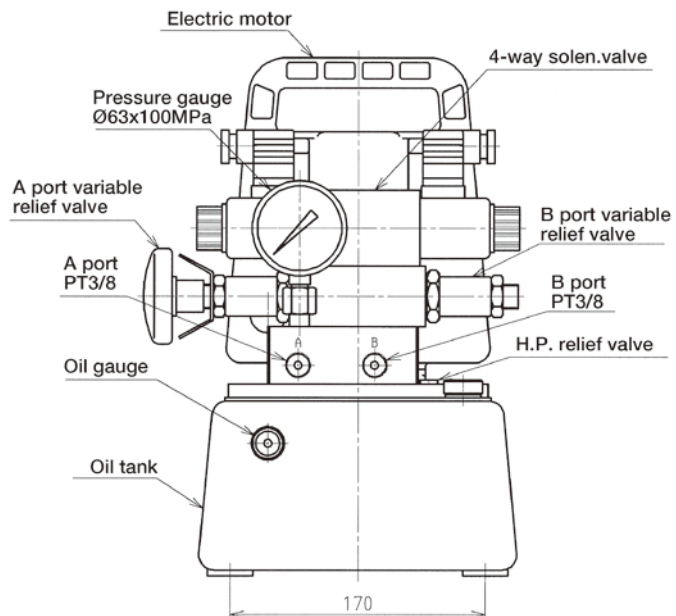
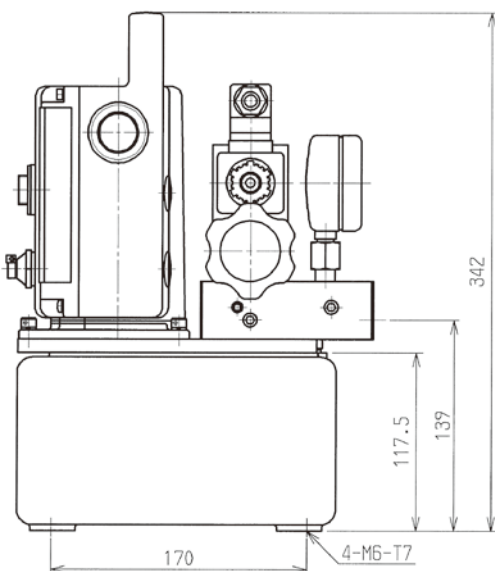
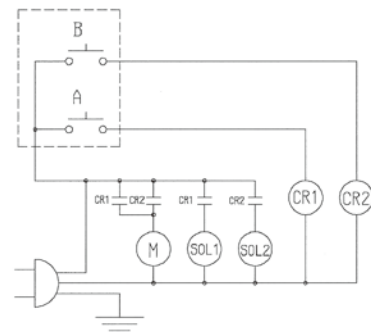



# Double Acting

## UP-45SVG-8A UP-45SVG-8H

UP-45SVG-8A(8H) (Pressure gauge, Standard tank 3 ℓ)  
UP-45SVG-8H(8HL) (Pressure gauge, L tank 5 ℓ)



<b>Valve type</b>	Solenoid 4way-3position
<b>Switch</b>	Pendant switch / A and B button
<b>Accessories</b>	Pressure Gauge Ø60
<b>Feature</b>	For Double Acting cylinder by solenoid valve.

### Advance

When A switch is pressed, then the motor starts. When A switch is released, the cylinder can be stopped but not hold on advance.  
( For hold type, 8SP is recommended)

### Retraction

- 8A : When B switch is pressed, then the motor starts as well as a cylinder extends. When B switch is released, the cylinder can be stopped but not hold on retraction.
- 8H : When B switch is pressed, then the motor starts as well as a cylinder retreats. Even though B switch is released, the cylinder can NOT be stopped. The cylinder retreats with external force. Since the residual pressure becomes zero at center, it will be smooth to attach and detach the coupler.

Model	Electric Motor	Mortor kW (2,000rpm)	Voltage(AC) 50Hz/60Hz	Amps	Output Flow Rate(Lpm)		Oil Volume (Litre)		Weight (Including oil)			
					7Mpa(70Bar)	70Mpa(700Bar)	Tank	Effective				
<b>UP-45SVG-8A/8H</b>	Commutator, Single phase	0.45	220/230	4.5	2.5	0.35	3.0	2.0	18.5Kg			
			100/110	9.0								
<b>UP-45SVG-8AL/8HL</b> (Large Tank)			220/230	4.5						5.0	4.0	20.9Kg
			100/110	9.0								

### <Dimensions> (mm)

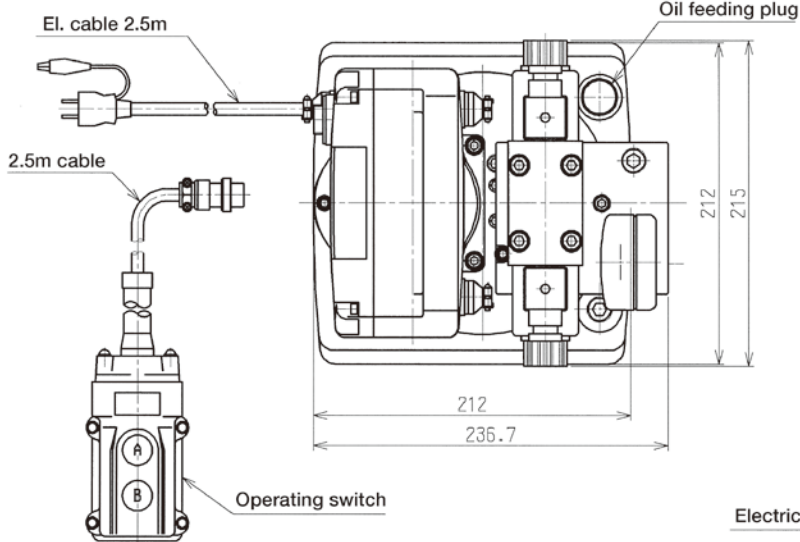

### <Hydraulic circuit>

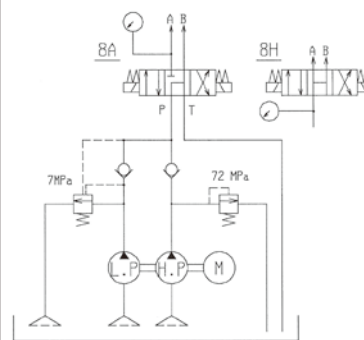

### <Electric circuit>

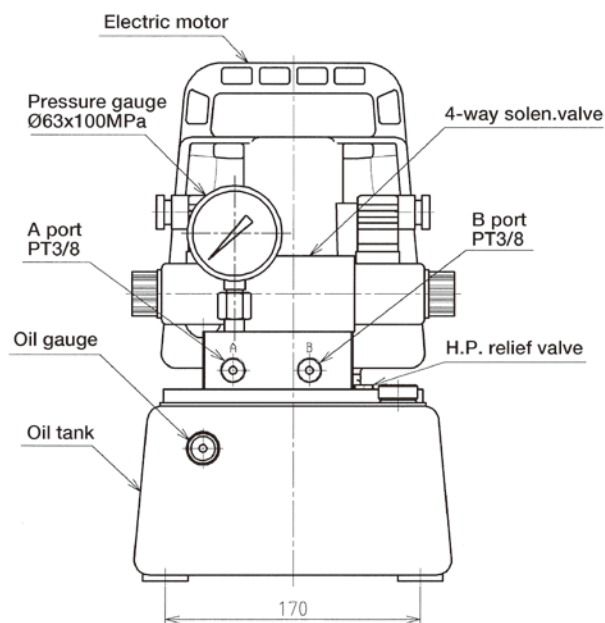
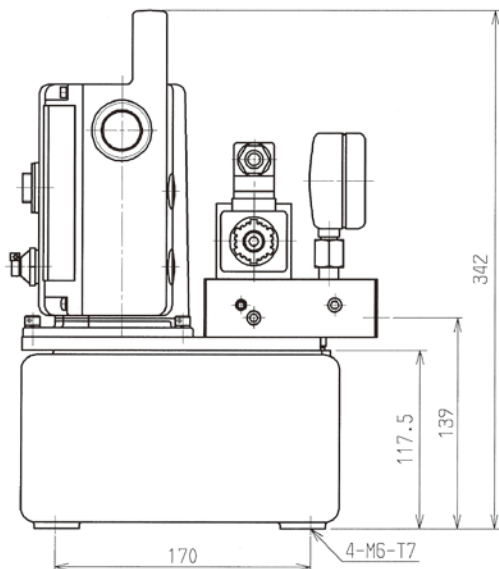
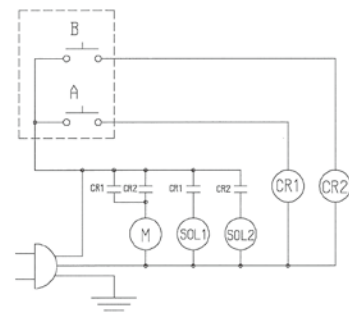

---

## **Nittoh Zohki Co.,Ltd.**

**Sales office :**

2-4-10 Kamezawa, Sumida-ku, Tokyo 130-0014 Japan  
Tel. +81-3-3625-6551 Fax.+81-3-3625-6553

**Factory :**

585 Takashi, Mobara-shi, Chiba-Ken 297-0029 Japan  
<http://www.nittohpower.jp>